

Threaded End Connection

Series F Carbon Steel

- NACE Standard
- Lever Operated Ball Valve
- 3000 PSI WP
- 1/4" Through 1"
- Bolted Body Construction
- Meets API 641 Emissions Standard
- Forged Body and Adapter
- Rugged Bolted Construction
- Low-Torque Operation
- Multi-Seal Seats
- Maintenance Free
- Fire Safe Design

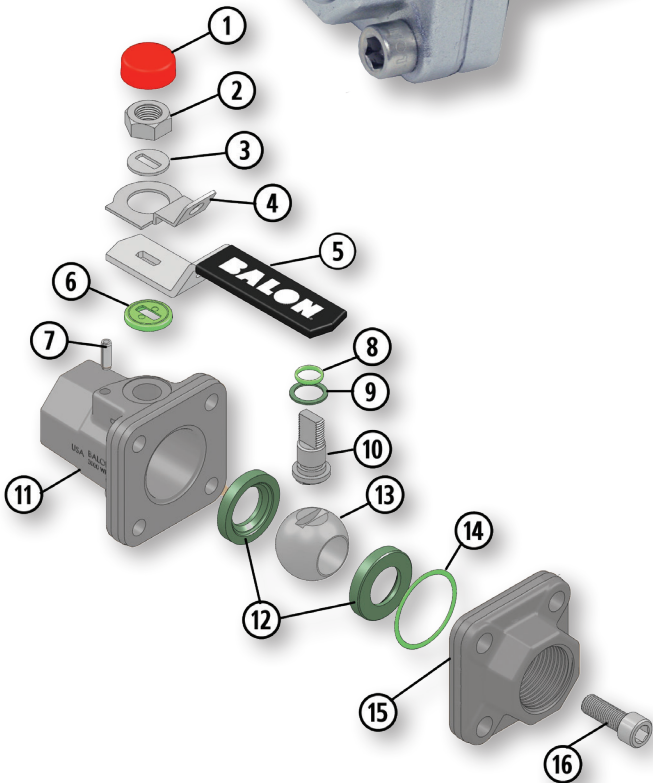
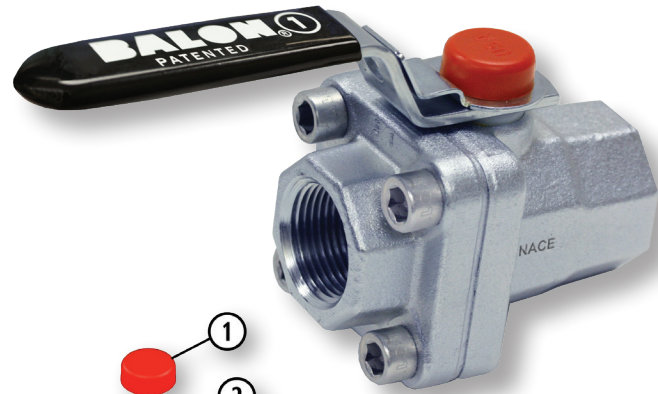

Material Description

ITEM	PART NAME	MATERIAL (NACE)
1	Weather Guard	Polyethylene
2	Stem Nut	Carbon Steel
3	Spacer	Carbon Steel
4	Lock Plate	Carbon Steel
5	Handle	Carbon Steel
6	Stem Washer	Acetal
7	Stop Pin	Carbon Steel
8	Stem O-Ring	Fluorocarbon
9	Stem Seal	TFE
10	Stem	316 Stainless Steel
11	Body	ASTM A105, Normalized/A350 LF2 CL1
12	Seat	Nylon (TFE Optional)
13	Ball	316 Stainless Steel
14	Body Seal	Fluorocarbon
15	End Adapter	ASTM A105, Normalized/A350 LF2 CL1
16	Body Bolts	ASTM A193 B7M/A320 L7M

* Handle and lock device are standard.

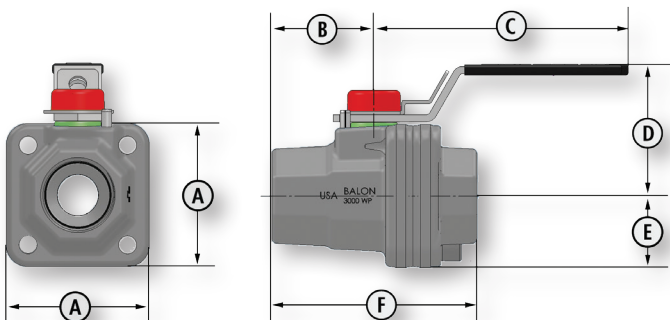

Dimensional Data

SIZE	CATALOG NUMBER		PORT	WP	A	B	C	D	E	F	LBS.	Cv
	NACE TRIM 316 SS BALL & STEM											
.25 x .375 x .25	1/4F-F03N-SE		.37	3000	1.75	1.12	3.50	1.88	0.88	2.25	1.0	-
.50 x .375 x .50	1/2R-F03N-SE		.37	3000	1.75	1.19	3.50	1.88	0.88	2.38	1.0	6
.50 x .50 x .50	1/2F-F03N-SE		.50	3000	1.92	1.38	3.50	1.96	0.96	3.00	3.3	-
.75 x .75 x .75	3/4F-F03N-SE		.75	3000	2.62	1.81	4.87	2.56	1.31	3.62	3.3	-
1 x .75 x 1	1R-F03N-SE		.75	3000	2.62	1.88	4.87	2.56	1.31	3.75	3.3	30